

BUSBI

Firefly



USE OF ELECTRIC SCOOTERS

LEGAL WARNING:

- United Kingdom law – This e-scooter is not to be used on public roads, cycle paths or pavements.
- Only to be used on private land and with the landowner's permission.

IMPORTANT!

Read these instructions carefully and keep for future reference

Do not use the e-scooter when under the influence of medication or alcohol.

The user should check the limits of use in accordance with the local regulations (e.g. use in pedestrian areas, on-roads).

Cruise control enabled by default.

Watch for pedestrians and others in your vicinity when riding.

Always wear a helmet and suitable footwear when riding this e-scooter.

Ensure your battery is fully charged before use.

This product is not a toy, and is intended for riders aged 16+ years.

PLEV Class 2 - Designed to carry a single rider.

Do not use this e-scooter in rain, snow or icy conditions.

Read this manual and all warning labels on the product before use.



Additional Information

For more guidance and support to help you get started, please visit: busbistore.com/product-support, or simply open the camera app on your mobile phone, and point the camera at the QR code below:



Warnings

The following symbols and words are used in this user manual to signal and warn against **personal injury** or damage to property. Warnings are intended to draw attention to potential dangers.

Failure to follow a warning, may result in injury to yourself or other people, as well as causing damage to property. Please read and follow all warnings.



DANGER

This warning identifies a hazard with a high degree of risk, that could result in serious injury or death if not avoided.



WARNING

This warning identifies a hazard with a moderate degree of risk, that could result in serious injury if not avoided.



CAUTION

This warning identifies a hazard with a low degree of risk, that could result in minor or moderate injury if not avoided.



NOTE

This warning calls attention to potential property damage.

Table of Contents:

Section:	Page	Section:	Page
1. General Information.	4	6. General Maintenance.	19
1.1 Warranty.	4	6.1. Stem Locking Mechanism.	19
1.2 Conditions of Use.	4,5	6.2. Brake Adjustment and Maintenance.	19
2. Getting Started.	6	6.3. Adjusting the Mechanical Disc Brake.	19
2.1 Package Contents.	6	6.4. Brake discs.	20
3. Preparing for First Use.	8	6.5. Changing the Brake pads.	20
3.1 Assembly.	8,9	7. Cleaning and Storage.	20
3.2 Brake Cables – Fitment.	10	8. Further Guidance for safe use.	21
3.3 Folding and Unfolding the Busbi Firefly.	10,11	8.1. Weight limits.	22
3.4 Charging.	11	8.2. Maximum travel distance.	22
3.4.1 Connect the Charger.	11	9. Safety Features.	23
3.4.2 Charging Complete.	11	10. Busbi - Reducing Waste.	24
4. Riding your Busbi Firefly.	12,13	10.1 Disposal.	24
4.1 Braking.	14		
4.2 Display Console.	15	Annex A	
4.3 Lights – Operation.	15	Table 1 Inspection Schedule.	25
4.4 Speed modes.	15	Table 2 Firefly Specifications.	26
5. Battery Charging.	16	Table 3 Charger Specifications.	26
5.1. Battery Care and Safety.	16	Table 4 Firefly Dimensions.	26
5.2. Using the Battery Charger.	16	Table 5 Battery specifications.	27
5.3. Charging Procedure.	17	Declaration of Conformity.	28
5.4. Battery.	17		
5.5. Battery Life.	17	Serial Number Identification.	29
5.6. General Precautions.	17,18		
5.7. Battery service life.	18	Appendix A	
5.8. Using the battery.	18	Cable lock accessory - operation	31

READ BEFORE USE

1. General Information:

This instruction manual will provide you with the information you need to use and maintain your Busbi Firefly e-scooter.

Please read and retain these instructions for future use.

This manual contains important instructions for safety and care.

It is the responsibility of the user to read this manual and to follow these instructions before using the product.

Failure to follow these instructions exposes the rider to the risk of injury or death.

Regular checks and maintenance are necessary to prevent premature wear or damage to components which may result in an accident and or damage to your e-scooter.

Drawings used throughout this manual, may differ from actual model specification.

1.1 Warranty.

Our Warranty does not cover normal wear and tear, damage caused by accidents, improper use, excessive loads, improper assembly or maintenance, and damage caused by modification. **For more information, please visit:** busbistore.com/warranty

1.2 Conditions of Use.

- At the time of manufacture, it is illegal to use an e-scooter on public roads, pavements, cycle lanes or bridleways in the United Kingdom.
- Before use, read this manual carefully ensuring that you have understood all information.
- This e-scooter is designated PLEV Class 2.
- This e-scooter is intended to be used by one rider at a time.
- This e-scooter is to be used by persons aged 16 years and above.
- You may use an e-scooter on private land, where the owner has given permission.
- This e-scooter is not intended for use on rough uneven ground, doing so may lead to a fall and serious injury.
- This e-scooter must be properly maintained in accordance with these instructions.
- Periodically inspect your e-scooter confirming it is in safe working order.
- If you are in any doubt over the safe working order of your e-scooter, stop using it immediately and consult a competent tradesman.
- Failure to comply with any warnings may result in injury to persons and property, and/or cause premature and potentially irreversible damage to your electric scooter.
- This e-scooter incorporates an electric hub motor located in the front wheel.
- The hub motor is activated when the scooter is switched on and the throttle lever is pressed.
- The hub motor drive disengages when the brake lever is pulled.
- This e-scooter is electronically limited to a maximum speed of 25km/h.
- Do not ride the e-scooter in rain, snow or icy conditions.
- Do not use the scooter when under the influence of medication or alcohol.

- Wear a helmet at all times when riding your e-scooter.
- Wear appropriate footwear when using this e-scooter.
- Your Busbi Firefly has a waterproof rating of IPX4, this means your Busbi Firefly is protected against splashes of water.
- This e-scooter must be properly maintained according to these instructions.
- Carry out periodic checks as described in this manual to ensure your e-scooter is in safe working order.
- Read this manual carefully and ensure that you have understood all the product information before using it.
- **The e-scooter is delivered with cruise control enabled.**



CAUTION

You are advised to engage a professional tradesman to perform maintenance on your e-scooter every six months, to ensure it is in good working order and safe to use.

It is the owner's responsibility to ensure that all components are in safe working order before use.

Choose a safe place, away from traffic, to familiarise yourself with your new electric scooter. The hub motor may start in a sudden forceful manner, check that your handlebars are straight and that the path is clear.

Take time to familiarise yourself with riding and controlling your e-scooter to avoid a serious accident.

Ensure you are in good health before riding your e-scooter.

In case of poor weather conditions, proceed with care and adjust your speed and reactions accordingly.

The user must comply with the requirements of national regulations when using the electric scooter on public roads (for example, lighting and signalling).



WARNING

As with any mechanical component, a vehicle is subject to high stresses and wear.

The various materials and components may react differently to wear or fatigue.

If the expected service life for a component has been exceeded, it may break suddenly, therefore risk causing injuries to the user. Cracks, scratches and discoloration in the areas subject to high stresses indicate the component has exceeded its service life and should be replaced.

IMPORTANT!

For your safety: Before each and every use, carry out the inspection schedule described at **Annex A, Table 1**, found at the end of this instruction manual.

2. Getting started.

Attention: Please fully charge your Busbi Firefly before first use.

Your Busbi Firefly e-scooter is a two wheeled electric scooter, powered by a Lithium-ion battery located inside the handle bar stem, and a hub motor incorporated in the front wheel.

Your Busbi Firefly does not require connection with any external devices such as mobile phones in order to operate.

Attention: Your Busbi Firefly is delivered with **cruise control enabled**. Please familiarise yourself with this function before riding.

2.1. Package Contents.

Please check the contents as listed below and retain your packaging in case the need to return your purchase.

Drawings used throughout this manual, may differ from actual model specification.

Eco Friendly
Packaging



User
Manual



Battery
Charger

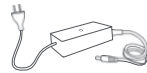

Extension
Nozzle



Allen
Key



Cable
lock.

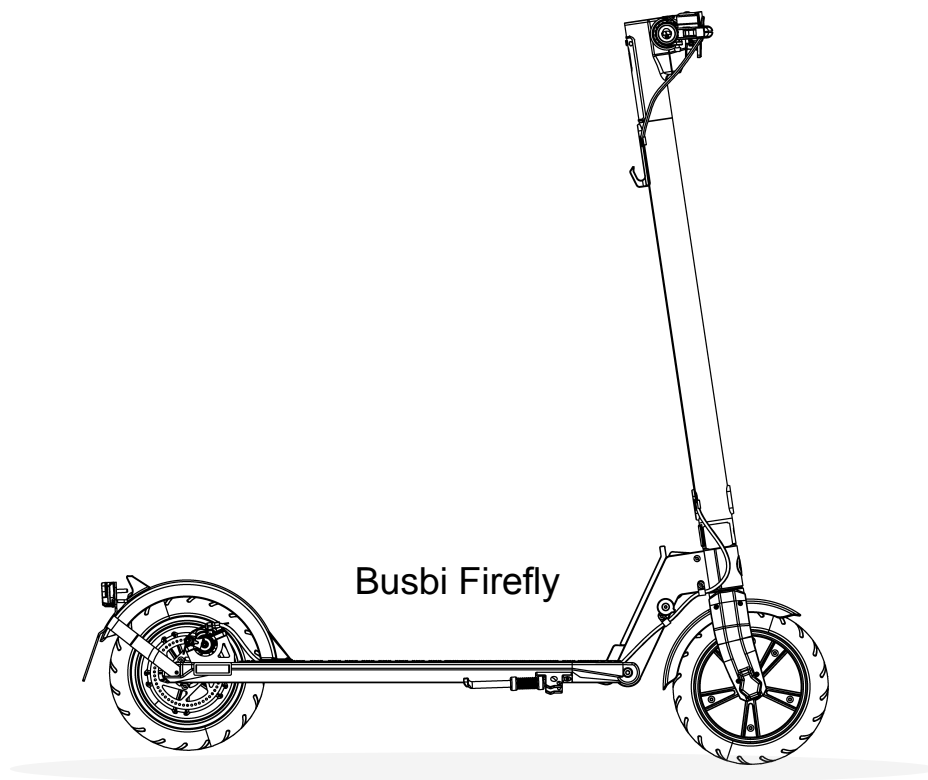

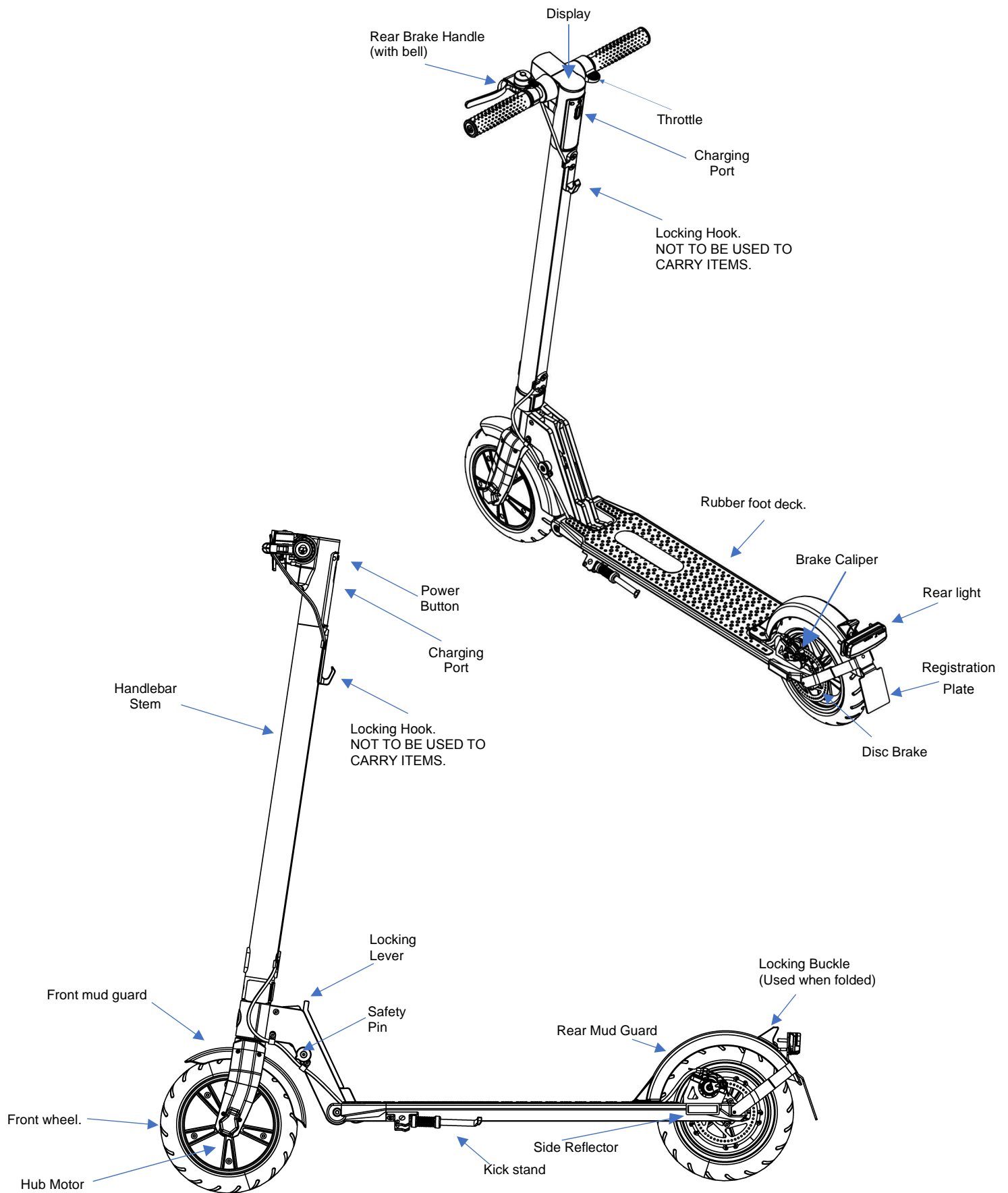

3. Preparing for first use:

Open the box and carefully take out all the parts, confirming the contents.

Please retain the packaging, this will allow return of the product in the event of any problems.



3.1 Assembly.

Place the e-scooter on the floor.

Push straight down on the rear mud guard and hold, so as to release the locking hook from the buckle.

Whilst holding down the rear mud guard, pull the handlebar stem up and forward until you hear the handlebar locking mechanism engage with a 'click'.

Place the scooter onto the kick stand.

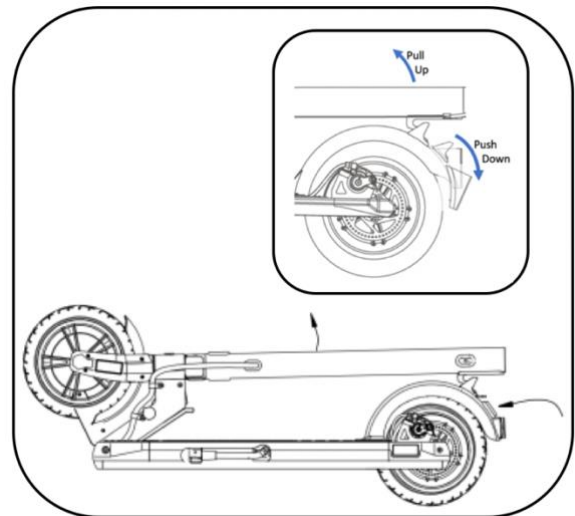

Using the Allen key provided, unscrew and remove the two bolts holding the locking hook to the handlebar stem.

Remove the plastic stopper from top of the handlebar stem. *Retain the plastic stopper with your packaging in case of return.*

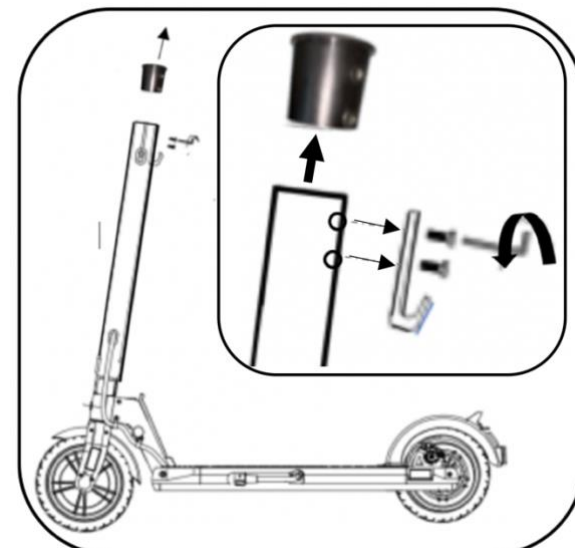

Confirm no debris such as packaging materials or other obstructions have become lodged in either the male or female connectors.

Observe the the correct orientation and key position.



Gently introduce the handlebar assembly into the handlebar stem, and push home.



Align the two bolt holes of the handlebar assembly neck with the holes in the stem. Re-position the Locking Hook and secure the two bolts through the three parts using the Allen key provided. Attention: Take care not to cross thread the screws.

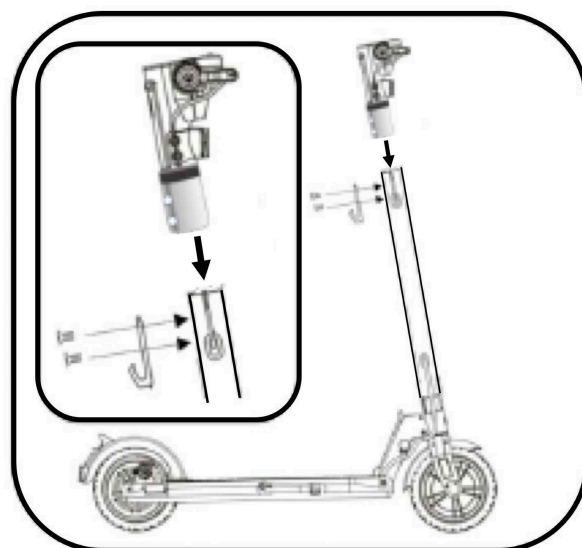

3.2 Brake Cable – Fitment

For assistance please visit www.busbistore.com/videos

- Depress the brake lever and insert the nipple of the brake cable into the brake lever bracket.
- Thread the cable through the slot in the brake lever until the sheath fits into the port on the brake lever.
Attention: You must pull on the sheath to perform this operation.
- Release the brake lever.
- Now thread the brake cable through the locking hook collar.
- Check the brake operation by pulling the brake lever and confirm brake caliper movement accompanied by inability to move the scooter through pushing.
- If necessary adjust the brake caliper see, Section 6.2



3.3 Folding and Unfolding the Busbi Firefly.

For assistance please visit www.busbistore.com/videos

Please take time to view our helpful video by scanning the QR code found in the introduction or by visiting: [busbistore.com/videos](http://www.busbistore.com/videos)

The Busbi Firefly is fitted with a unique locking mechanism, providing added safety. The method of unfolding is as follows:

Unfolding the Busbi Firefly

- Push straight down on the rear mud guard and hold, so as to release the locking hook from the buckle.
- Whilst gently pushing down on the rear mud guard, pull the handlebar stem up and forward until you hear the handlebar locking mechanism engage with a 'click'.
- Place the scooter onto the kick stand.

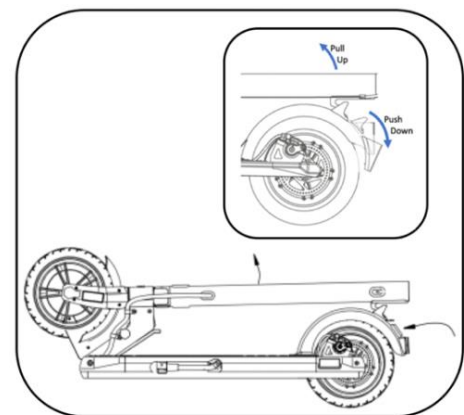

WARNING

Before riding the e-scooter, confirm the Safety Pin is in the fully locked home position.
(Red Stopper should be in contact with the scooter frame).

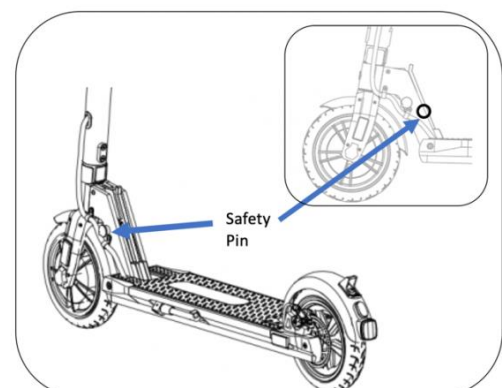

Attention: Take control of the handlebar stem as it collapses to the folded position.

Folding the Busbi Firefly:

Note: If the safety pin is not pulled fully out, the locking lever will not move and you will be unable to fold the handlebars; this is a safety feature.

- Ensure the Busbi Firefly is powered off.
- Hold the handlebar stem.
- Fold the kickstand away.
- Pull the safety pin on the left hand side of the frame, and with the safety pin held in the out position, firmly pull the locking lever down towards the foot deck of the scooter.
- As the handlebar stem folds down, guide it to ensure the locking hook engages with the locking buckle

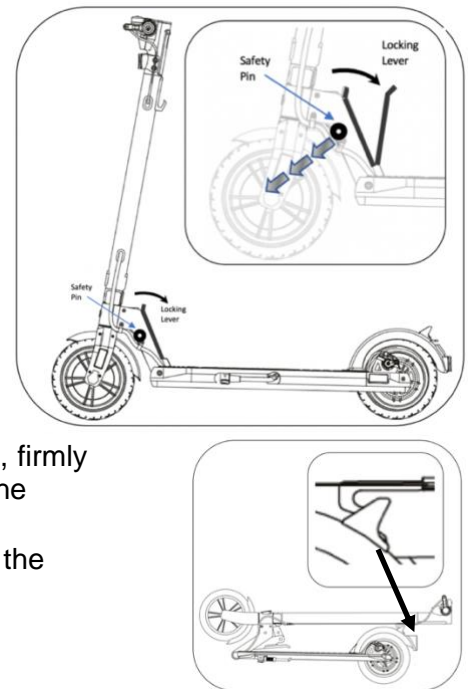

3.4 Charging.

Before first use, please fully charge your e-scooter.

(See further guidance on page: 16). Before charging, ensure the charging port is dry and free from debris.

3.4.1 Connect the Charger

Use the included charger and connect it to the charging port. Now connect the 3 pin plug to the mains outlet. Observe the charging light on the charger.

3.4.2 Charging Complete.

When fully charged, a **green light** on the charger indicates charging is complete. Disconnect the power supply from the charging port and ensure the charging port cover is closed securely.

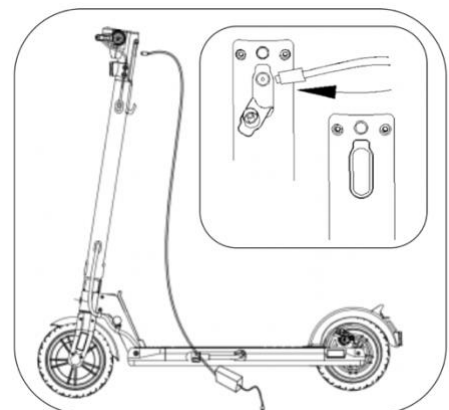

WARNING

Failure to observe safe charging conditions.
Risk of fire, explosion and Injury.

- Charge in a well-ventilated space.
- Do not attempt to charge - if the charging port or power adaptor is wet.
- Only use charger specified by the manufacturer.
Manufacturer: Shenzhen Fuyuan Power Co., Ltd., Model: FY0634201500
- Ambient temperature must be 0-40 °C during charging.
- The battery will not charge outside of these temperature limits.
- Risk of Fire: Do not attempt to disassemble the charger.
- No user serviceable parts.



WARNING

Cruise Control is factory enabled on this e-scooter

Cruise control is engaged when in motion and the rider holds the throttle for 8 seconds at a constant speed. The rider may release the throttle and the e-scooter will maintain the constant speed attained when cruise control initiated.

Cruise control is disengaged by pulling the brake lever.

Disabling Cruise Control.

To disable the cruise control function: With the Busbi Firefly powered on, press the power button 7 times in quick succession; cruise control will be disabled.

To re-enable Cruise Control, repeat the above operation.



WARNING

Altered balance and handling characteristics due to additional weight.
Risk of serious injury.

Do not hang bags or items on the locking hook.

4. Riding your Busbi Firefly.

Step 1:

Before each use of the e-scooter carry out the **Pre-Use Inspection Schedule** that can be found in Table 1, Annex A at the end of this manual.



Step 2:

Unfold the scooter in accordance with the instructions provided in section 3.

Press and hold the Power Button for 2 seconds located at the top of the rear face of the handlebar assembly.

The display will initialise and then display the speedometer.

Note: The speed setting will default to the last speed setting in use at Power Down.

Step 3:

Once the scooter is switched on, check the stand is folded away, place one foot on the foot deck and then begin pushing forward on the ground with the other foot, gaining momentum without using the throttle.

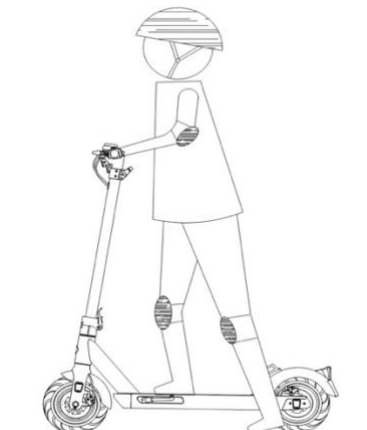

Step 4:

You must reach a speed of 3 km/h before the throttle will engage the motor. Once the threshold of 3km/h is reached, gently press the throttle and bring your other foot up onto the foot deck assuming a stable riding position.

Note: Forward motion is required to engage the motor. The motor will not engage from a standing start.

Step 5:

To brake, release the throttle lever and pull the brake lever gently applying pressure, as described in section 4.1.

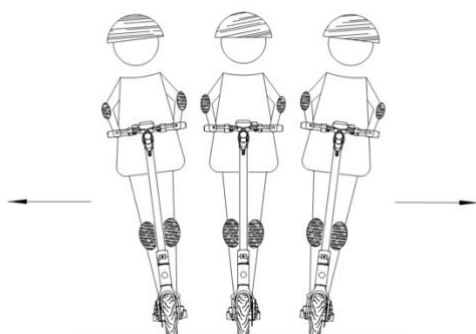
**IMPORTANT:**

- To avert any danger, sharp turns should always be avoided when traveling at high speed.
- Keep your body balanced when turning to avoid falling over due to high speeds or a shifting centre of gravity.

Step 6:

Once you have finished riding your Busbi Firefly, press and hold the On/Off button for 3 seconds to turn the scooter off.

4.1 Braking

- To slow down, simply release the throttle.
- To brake, pull the brake lever steadily increasing the force as required.
- The brake lever activates the rear disk brake and initiates proportional hub motor braking.
- Braking style should be adapted to the surface conditions and rider weight.



WARNING

Braking efficiency reduced due to wet or slippery conditions.
Risk of serious injury.

Allow extra stopping distance in wet or slippery conditions.



CAUTION

- Do not tighten your brake cable more than necessary at the brake calliper.
- Avoid locking the wheels through excessive brake pressure, this may cause a loss of control and balance.
- Never touch the brake disc with your fingers after using the brake system, as this will be very hot and may cause burns.
- Before each use, ensure the rear brake is in good working order.
- Damaged, frayed or rusty cables must be replaced immediately.
- Apply a suitable cable lubricant to brake cables every 3 months, to ensure freedom of movement.
- Take care to ensure no oil or contaminants come into contact with brake disks and brake pads.

4.2 Display Console

The display console, located on the handlebars, displays the status of the scooter, providing the rider with the following information.

1. Front Light Status (On/Off)
2. Speedometer / Speed Mode
3. Battery Level
4. Pedestrian Mode activated.

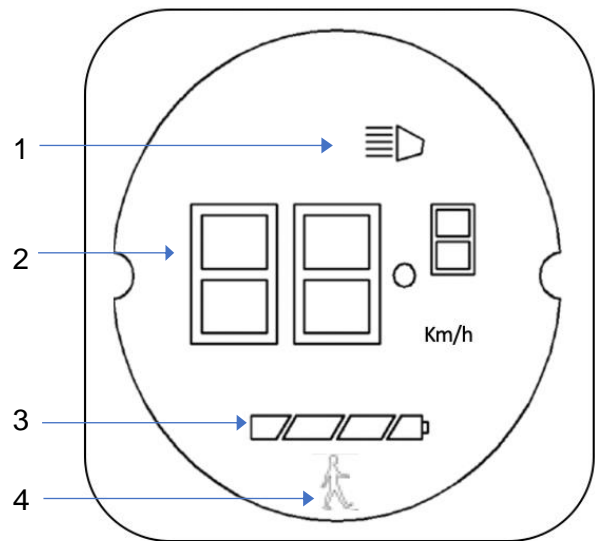

4.3 Lights

Front Light - Operation:

Press and release the Power Button swiftly once; the front light will illuminate. To switch the front light off, simply toggle the light off with the same action.

Rear Light - Operation:

The rear light operates independently of the power status of your Firefly, and is powered by 2 x AAA batteries. Press the button located on the underside of the rear light once to switch on, and press twice to switch off.

To replace batteries, gently prize open the combined lens and reflector assembly. When fitting new batteries, please observe the correct polarity.



4.4 Speed modes:

With the e-scooter powered on, press and hold the Power Button for 2 seconds to toggle to the next speed mode. The speed mode will be displayed briefly before the display returns to a speedometer display.

- **Speed mode 1:** 15 km/h [9.3 mile/h] max speed
- **Speed mode 2:** 25 km/h [15.5 mile/h] max speed

Pedestrian mode is designed to allow assistance to the rider when pushing the scooter and not riding.

- **Speed mode 3:** **[Pedestrian Mode]**
 6 km/h [3.7 mile/h] max speed

Press and Hold Power Button for 3 seconds to power off.

5. Battery Charging

5.1. Battery Care and Safety.

- Do not store or charge the battery at temperatures outside of the stated limits (see specifications).
- Do not puncture the battery.
- Refer to your local laws and regulations regarding battery recycling/disposal.
- A well-maintained battery can perform well even after many miles of riding.
- Charge the battery after each ride to avoid draining the battery completely.
- When used at room temperature (20 °C) the battery range and performance is best.



WARNING

- Do not leave your scooter unattended when charging.
- Do not attempt to disassemble the battery.
- Risk of fire. No user serviceable parts.
- Do not ride when the ambient temperature is outside of the operation temperature (see specifications), because low/high temperature will limit the maximum power/torque. Doing so could cause personal injury or property damage due to slips or falls.

5.2. Using the Battery Charger.

Before charging the battery, note the following:

- Follow the instructions on the battery charger label.
- The charger is for indoor use only.
- Always protect the charger from rain and moisture.
- Do not use this charger near explosive gases or corrosive substances.
- Do not shake or hit the charger or allow it to fall.
- The operating temperature range of this charger is between 0 and 40°C.
- Do not attempt to disassemble the charger.
- In the event of a fault, immediately stop using and have the unit repaired by a qualified person.
- Only use the charger supplied with your electric scooter to avoid damage.
- When charging, the battery and charger should be at least 10 cm away from the wall and in a dry, well-ventilated place.
- Do not place anything in the direct vicinity of the charger during use.
- Avoid prolonged contact with the charger while charging as the unit will become hot to touch during normal operation.
- Do not place the charger in an unstable position.
- Do not cover the charger to avoid overheating while charging.
- Do not immerse the product in water.
- Avoid any contact with water while recharging the battery.
- Do not use the charger with a damaged power cord or plugs.
- Ensure the charger plug is inserted fully into the mains outlet.
- Do not short-circuit the charger pins using a metal object.
- Disconnect the charger from the mains power source before connecting and disconnecting from the Busbi Firefly e-scooter.
- The external flexible cable of this product cannot be replaced; If the cord is damaged, the product should be discarded.

5.3. Charging Procedure.

- Open the silicone cap beneath the power switch, covering the charging port.
- Check the charging port is dry and free from debris.
- Insert the charger plug into the battery charging port.
- Plug the charger's power cord into the mains port.
- When charging, the LED on the charger will turn red to indicate proper operation.
- When LED changes to green, this indicates the battery is fully charged.
- Unplug the mains plug and then disconnect the cable from the charging port.
- Close the battery port cap.

CAUTION:

Charging for too long may shorten battery life:

- Do not leave your Busbi Firefly connected to the charger overnight.
- Do not charge the battery if the charging plug or socket are wet.
- Always fully charge your Busbi Firefly battery before first use and each time you subsequently charge it. This will maximise the service life of your battery.
- For typical charging times: see "Battery Specifications".

5.4. Battery

This electric scooter is equipped with a high-quality Lithium-ion battery.

Lithium-ion batteries do not suffer from memory effect and have a wide temperature tolerance range from -10 to 40°C.

The battery is contained within the handlebar stem.

To maximise battery life and to protect the battery from damage, please follow the use and care instructions below.

5.5. Battery Life

After charging your battery, it is advisable to allow 20 to 30 minutes before riding.

The operating life of your battery depends on several factors of use:

- Rider's Speed and acceleration behaviour.
- The weight of the rider.
- Gradient of riding route.
- Tyre inflation.
- Wind conditions.
- Starting and stopping frequency.
- Outdoor temperature.

5.6. General Precautions.

As memory effect is not a concern with lithium-ion batteries, it is recommended to recharge the battery on a regular basis, or after each use.

To maximise the service life of your battery, please observe the following recommendations:

- Avoid very hot and very cold places (ideal charging temperature 20°C)
- Allow the battery to cool for 30 minutes after riding your Busbi Firefly.
- If your Busbi Firefly stops working due to overheating, place it in a cool, dry place and wait for the battery and hub motor to cool before using it again.

- Use only the specific charger supplied to charge the battery.
- Do not use any power supply or electrical device other than the one supplied with the device.
- Only charge the battery in a well-ventilated area.
- Do not expose the battery to heat or charge the e-scooter in direct sunlight.
- Do not disassemble or modify the battery case built into the footboard compartment of the scooter.
- Do not connect the (+) and (-) connections of the battery plug with a metal object.
- Do not expose the battery to liquids.
- Do not use a damaged battery.
- Do not continue to charge the battery if it is not fully charged after the theoretical charging time, see “Battery Specifications” below.
- Do not use the battery if it emits an unusual smell or becomes unusually hot.
- If the e-scooter is not used frequently over a period of time, it should be fully charged every 60 days.
- The scooter should be stored in a dry, protected place.
- at a temperature between 5 and 35°C.
- Do not leave the battery charging for an extended period without attention.
- If the battery leaks, be careful not to let the liquid come into contact with the skin or eyes. If this happens, wash with plenty of water and seek medical attention.
- For battery repairs or replacement, contact a qualified technician.

5.7. Battery service life

Battery service life is dependent on usage profile.

Do not expose the battery to temperatures lower than -10°C or higher than 40°C. Doing so may affect its operation and life.

Batteries can suffer from ageing of their performance after numerous charges, this will be determined by usage habits.

5.8. Using the battery

To ensure maximum battery life and to protect the battery from damage, please follow the use and care instructions below:

- When the battery charge state falls to 25%, the battery should be recharged.
- When the battery icon on the display appears empty and flashes, it means that the voltage is low and the Busbi Firefly scooter will not have enough power to operate normally. In these circumstances switch off the Busbi Firefly and recharge the battery.



NOTE

Do not use the Busbi Firefly when the battery is low or the system requires a safe shutdown. Battery service life will be shortened if you continue to use the Busbi Firefly while the battery voltage is low.

6. General Maintenance:

6.1. Stem Locking Mechanism.

When the stem is correctly locked in the upright position, there should be no free play between the stem and folding mechanism.

The folding system must be checked regularly and at a maximum interval of **every three months**, to ascertain if any free play is noticeable in the stem.

If free play (waggle) of the handlebar stem is experienced the following procedure should be carried out to rectify the situation:

Carefully ease back the plastic collar at the base of the handlebar stem.

Using a 4mm Allen key, tighten each bolt in turn.

Repeat this procedure on the opposite side.

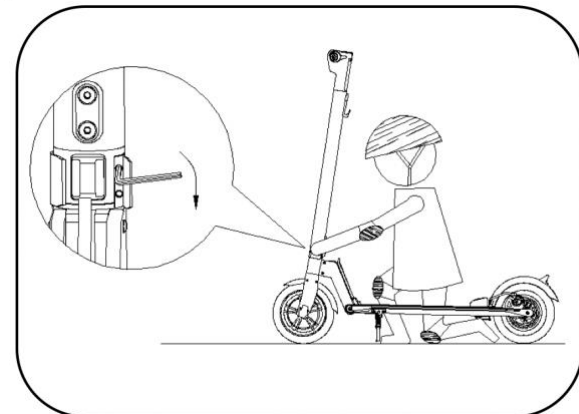
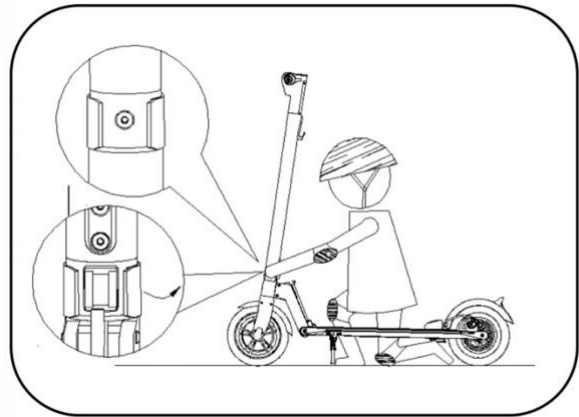

6.2. Brake Adjustment and Maintenance:

Wear and tear of the braking system is normal after frequent use of the Busbi Firefly. Some adjustment of the braking system will be required to maintain effective braking. The following procedures should be followed:

6.3. Adjusting the Mechanical Disc Brake.

The brake pads exert pressure on a disc attached to the wheel hub.

The pressure intensity is controlled by a brake lever via a cable.

If the brake is too tight or too loose, the brake cable must be adjusted to align the calliper with the brake disc.

To align the mechanical disc brake calliper, loosen the fastening screws of the brake calliper bracket. Gently pull the brake lever; the brake calliper will be drawn into the correct alignment. Hold the brake lever in this position while tightening the fastening screws of the calliper bracket.

Check the inner pad is 0.2 - 0.4 mm from the disc. If this is not enough, tighten the pad positioning screw until there is a 0.2 - 0.4 mm gap between the pad and the disc.

To adjust the outer pad, adjust the brake cable tension to achieve a gap of 0.2 - 0.4 mm at the calliper or brake lever level.

Never allow oil or any other lubricant to contaminate the disc or pads. If this happens, the pads and disc should be degreased or replaced.

Check the alignment of the brake pads by turning the wheel, observe and listen, ensuring the wheel turns freely.

6.4. Brake discs.

The Busbi Firefly is equipped with a front wheel 11 cm (4.3 inch) diameter brake disc. A nut and locknut system on the brake calliper allows you to adjust the cable tension and braking force, which will vary over time according to the wear of the brake pads.

6.5. Changing the brake pads.

Brake pads are standard, replace them when they no longer have a friction component. Remove the wheel and remove the worn brake pads from the brake calliper. Position the new pads in the calliper so that the braking surfaces are in contact. Do not touch the braking surfaces. Insert the brake pads one after the other into the brake callipers. Now adjust and test the brakes.

7. Cleaning and Storage.

Use a soft, wet cloth to wipe the frame clean. Hard to remove dirt can be scrubbed with a toothbrush, then cleaned with a soft wet cloth.

Do not wash your Busbi Firefly with alcohol, petroleum, acetone, or other corrosive solvents. These substances may damage the appearance and internal structure of your Busbi Firefly. Do not wash your Busbi Firefly with a power washer or hose.



WARNING

Ensure your Busbi Firefly is powered OFF and the charging cable is unplugged before cleaning; otherwise you may damage the electronic components.

Storage Temperatures: -10 to +40°C.

IMPORTANT!

8. Further Guidance for safe use:

- Previous experience such as riding bicycles and skateboarding can be useful when learning to familiarise yourself with the Busbi Firefly e-scooter.
- For your safety before each and every use, please perform the **Inspection Schedule** found in **Table 1 at Annex A** of this instruction manual.
- For your personal safety and protection, wear adequate protection when riding the Busbi Firefly: appropriate footwear, helmet, gloves, knee pads, elbow pads etc.
- Do not modify your Busbi Firefly, this will invalidate any warranty and may reduce performance, cause damage and potentially cause serious injury.
- Do not fit accessories or additional items to Busbi Firefly that are not approved by the manufacturer.
- When riding be aware of your surroundings and always look in the direction of travel.
- Do not ride on wet roads, rainy weather or icy conditions.
This could result in loss of traction and cause personal injury and irreparable damage to your e-scooter.
- Ride responsibly, adjusting your speed to match conditions and your ability.
- Operating the scooter under the influence of alcohol and/or drugs is prohibited and would likely result in serious injury.
- Always keep your hands on the handlebars when using the Busbi Firefly.
- You are accountable for your actions and should ride responsibly, so as not to cause damage and harm to persons or property.
- Avoid driving on unpaved roads or in areas with obstacles.
- Always keep both feet on the foot deck when riding.
- Keep in mind at all times that you can seriously injure yourself by losing control, colliding or falling off an e-scooter.
- Do not use the Busbi Firefly in an unsafe environment where flammable products, vapours, liquids, dust or fibres may be present and cause a fire or explosion.
- It is prohibited to mount a seat on the electric scooter for use in a seated position. Your Busbi Firefly is designated a Class 2 PLEV.

8.1. Weight limits

- Maximum 100kg
- Minimum 20kg
- Observing the max and min weight limits the user's safety will avoid damaging the Busbi Firefly due to overloading.
- The combined weight of the user and belongings, must not exceed the maximum weight of 100kg.
- Exceeding the maximum weight or not meeting the minimum load weight of 20kg may cause the user to fall or be injured and may damage the Busbi Firefly.
- Failure to comply with the recommendations may result in the Busbi Firefly losing its ability to safely decelerate or stop while going downhill.
- It is forbidden for more than one person to ride the scooter.
- The Busbi Firefly is designed to be ridden by one person only. (Class 2 PLEV).

8.2. Maximum travel distance

- The maximum travel distance varies depending on several factors, such as:
- Terrain: Smooth, flat terrain increases the travel distance.
- Upward gradient reduces the distance.
- Avoid driving on steep slopes.
- User weight: The user weight affects the distance travelled.
- Ambient temperature: Storing and using the Busbi Firefly at the recommended temperature may increase the travel distance; using the Busbi Firefly outside of this temperature range reduces the travel distance.
- Speed and driving habits: Consistent, low operating speed increases the driving distance; conversely, frequent starting, stopping, accelerating and decelerating reduces the driving distance.
- Do not start and stop suddenly.
- Do not use the Busbi Firefly on slopes that are too steep in gradient.
- Accelerating on too steep a slope can cause the hub motor and battery to overheat.



WARNING! Protective equipment should be worn.

To avoid serious injury, always wear protective equipment: shoes, helmet, gloves, knee pads, elbow pads and wrist protectors.

9. Safety Features.

Lighting.

The front LED light fitted to your Busbi e-scooter is powered by the scooter battery.

The rear tail LED light is powered by 2 x AAA batteries (included).

Orange reflectors positioned left and right of the rear wheel, further enhance the visibility of the e-scooter.

The lighting system is a safety feature of your electric scooter.

Ensure that your lighting system is working properly before riding your e-scooter.

Bell.

A bell is installed on the handlebars.

The bell is a safety feature of your e-scooter allowing you to alert others of your presence, it must be installed on your handlebars.

Cable Lock.

For security and to prevent unauthorised use of your Busbi Firefly, a handy cable lock is included for your convenience.



NOTE

Theft or use by unauthorised person.

Risk of loss of property.

Owners are advised to lock the Busbi Firefly using the cable lock provided, this helps prevent use by untrained persons or minors.

10. Busbi - Reducing Waste:

Here at Busbi we do everything we can to use little or no plastic in the packaging of our products. The packaging that your Busbi Firefly has been protected by, and delivered in, has been designed to be minimalistic and plastic free. In addition, there are no coloured inks or varnishes used on the cardboard packaging, allowing ease of recycling.

10.1. End of Product Life; Disposal and Recycling:



Information on Waste Disposal for Consumers of Electrical & Electronic Equipment

This mark on a product and/or accompanying documents indicates that when it is to be disposed, it must be treated as

Waste Electrical & Electronic Equipment (WEEE).

Any WEEE marked waste products must not be mixed with general household waste, but kept separate for the treatment, recovery and recycling of the materials used.

For proper treatment, recovery and recycling; please take all WEEE marked waste to your Local Authority Civic waste site, where it will be accepted free of charge.

If all consumers dispose of Waste Electrical & Electronic Equipment correctly, they will be helping to save valuable resources and preventing any potential negative effects upon human health and the environment, of any hazardous materials that the waste may contain.



Please recycle your spent batteries.

Batteries should not be disposed of in unsorted municipal waste, but separately collected to facilitate the correct treatment and recycling of the substances they contain. The recycling of batteries ensures the recovery of these valuable materials and prevents any potentially harmful effects upon both the environment and human health.

Please contribute to battery recycling by segregating all spent batteries and actively participating in their collection and recycling. Various battery collection schemes will be in operation in different areas of the country. However, battery collection bins will be available at retail stores that sell batteries as well as at schools, libraries and other public buildings.



Warning; Explosive material.



No open flame; Fire, open ignition source and smoking prohibited

Annex A

Before each and every use, carry out the inspection schedule described below:

Table 1 - Inspection Schedule	
All parts.	Check and confirm all screws and fasteners are tightened correctly.
Handlebar stem folding system and lock	<ul style="list-style-type: none"> • Ensure folding system is free from debris and obstructions. • Visually inspect handlebars and handlebar stem for cracks, deformation or discoloration. • Ensure handlebar stem locks securely in position, and is unable to inadvertently fold when riding.
Tyres	<ul style="list-style-type: none"> • Check and adjust tyre pressure to 50 PSI. • Visually inspect tyres for cracks or foreign bodies. • Check tyre tread is adequate to maintain grip when riding.
Frame	<ul style="list-style-type: none"> • Visually inspect frame for cracks, deformation or discoloration.
Wheels	<ul style="list-style-type: none"> • Visually inspect for correct positioning and alignment. • Visually inspect axles and nut and bolt joints.
Brakes	<ul style="list-style-type: none"> • Test brake functionality.
Thumb operated accelerator	<ul style="list-style-type: none"> • Check operation and freely returns to zero position after release.
Lighting	<ul style="list-style-type: none"> • Test lighting functionality.
Bell	<ul style="list-style-type: none"> • Test bell functionality.
Battery charging port	<ul style="list-style-type: none"> • Ensure cover securely closed.
Foot deck anti-slip matt	<ul style="list-style-type: none"> • Ensure secure.
Mud guards	<ul style="list-style-type: none"> • Ensure secure. • Ensure not obstructing wheel rotation.

Table 2 – Firefly Specifications	
Battery	36 V 5.2Ah
Hub Motor	250W Average 350W Maximum.
Range	Up to 20 km
Charging	Charge port
Splash Resistant	IP X4 (Can withstand splashing of water)
Lights	Integrated front LED, Independent rear LED
Braking	Electronic and Hand Operated Disc.
Wheels	20.32 cm (8") Pneumatic with puncture resistant fluid.
Top Speed	25 km/h (15.5 mph)
Climb	17.5 % grade / 10 degrees
Weight Limit	100 kg
Storage Temperature	-10 to 40 °C
Operating Temperature	-10 to 40 °C

Table 3 - Charger Specifications	
Input Voltage	100-240AC, Output Voltage = 42VDC, Output Current: 1.5 Amps, Charger Manufacturer: Shenzhen Fuyuandian Power Co., Ltd., Model: FY0634201500 (Only Use Charger Provided)
Ambient Temperature while charging	0°C to 40°C

Table 4 – Firefly Dimensions	
Length x Width x Height	1100*440*1110 mm (Unfolded)
Weight	12 kg

Table 5 - Battery specifications

Type	Lithium-ion
Nominal Voltage	36V
Capacity	5.2 Ah
Number of cycles ($\geq 70\%$ capacity)	500 cycles
Maximum input	42V DC 1.5 Amp

EC DECLARATION OF CONFORMITY



THE EQUIPMENT WHICH ACCOMPANIES THIS DECLARATION IS IN CONFORMITY WITH THE FOLLOWING EU DIRECTIVES:

GENERAL PRODUCT SAFETY DIRECTIVE (2001/95/EC)
MACHINERY DIRECTIVE (MD) (2006/42/EC)
ELECTROMAGNETIC COMPATIBILITY (EMC) DIRECTIVE (2014/30/EU)
LOW VOLTAGE DIRECTIVE (LVD) (2014/35/EU)
BATTERY DIRECTIVE (2006/66/EC)
ROHS DIRECTIVE (2011/65/EU) WITH ITS AMENDMENTS COMMISSION DELEGATED DIRECTIVE (EU 2015/863)
REACH REGULATION (EC NO 1272/2008)

MANUFACTURER:

CMS Distribution Ltd.
CasOne, Freeway Dr, Castleford WF10 5EJ, United Kingdom

A copy of the Technical File for this equipment is available from the address above.

DESCRIPTION OF EQUIPMENT:

Model: **TT-EL-H853**
Marketed as: **Busbi Firefly.**
Designated as a Personal Light Electric Vehicle. (PLEV) Class 2.
An adult electric kick scooter, designed for recreational use.

Serial Number: **BF/853/XX/202X/XXXX**
EAN: 5051868215308

THE FOLLOWING HARMONIZED STANDARDS HAVE BEEN USED:

EN 60335-1:2012+AC:2014+A11:2014+A13:2017+A1:2019+A14:2019+A2:2019
EN60335-2-29:2004+A11:2018, EN60335-1:2012+A2:2019; BS 62233:2008
EN ISO 12100:2010
EN 17128:2020
EN 61000-3-3:2013/A1:2019
EN 61000-3-2:2019
EN 55014-1: 2017/A11:2020
EN 55014-2: 2015

AUTHORISED SIGNATURES OF MANUFACTURER

Services Director
CMS Distribution
Ltd. 20th April 2023

UKCA DECLARATION OF CONFORMITY



THE EQUIPMENT WHICH ACCOMPANIES THIS DECLARATION IS IN CONFORMITY WITH THE FOLLOWING GB Regulations:

General Product Safety Regulations 2005
Supply of Machinery (Safety) Regulations 2008
Electromagnetic Compatibility Regulations 2016
Electrical Equipment (Safety) Regulations 2016
The Waste Batteries and Accumulators Regulations 2009
The Restriction of the Use of Certain Hazardous Substances in Electrical and Electronic Equipment Regulations 2012
The REACH Enforcement Regulations 2008

MANUFACTURER:

CMS Distribution Ltd.
CasOne, Freeway Dr, Castleford WF10 5EJ, United Kingdom

A copy of the Technical File for this equipment is available from the address above.

DESCRIPTION OF EQUIPMENT:

Model: **TT-EL-H853**
Marketed as: **Busbi Firefly.**
Designated as a Personal Light Electric Vehicle. (PLEV) Class 2.
An adult electric kick scooter, designed for recreational use.

Serial Number: **BF/853/XX/202X/XXXX**
EAN: **5051868215308**





THE FOLLOWING HARMONIZED STANDARDS HAVE BEEN USED:

EN 60335-1:2012+AC:2014+A11:2014+A13:2017+A1:2019+A14:2019+A2:2019
EN60335-2-29:2004+A11:2018, EN60335-1:2012+A2:2019; BS 62233:2008
EN ISO 12100:2010
EN 17128:2020
EN 61000-3-3:2013/A1:2019
EN 61000-3-2:2019
EN 55014-1: 2017/A11:2020
EN 55014-2: 2015

AUTHORISED SIGNATURES OF MANUFACTURER

Services Director
CMS Distribution Ltd.
20th April 2023

Rating Plate: found on the underside of the foot deck of your Busbi Firefly:

BF/853/XX/202X/XXXX	
<p>WARNING: Read the instruction manual and all warning labels on the product before using this product. Use only the charger supplied with this product.</p> <p>ATTENTION: Lisez le manuel d'instructions et toutes les étiquettes d'avertissement sur le produit avant d'utiliser ce produit. Utilisez uniquement le chargeur fourni avec ce produit.</p> <p>VARNING: Läs bruksanvisningen och alla varningsetiketter på produkten innan du använder denna produkt. Använd endast laddaren som medföljer denna produkt.</p> <p>WARNUNG: Lesen Sie die Bedienungsanleitung und alle Warnhinweise auf dem Produkt, bevor Sie dieses Produkt verwenden. Verwenden Sie nur das mit diesem Produkt gelieferte Ladegerät.</p> <p>Imported by: CMS Distribution Ltd, CasOne, Freeway Drive, Castleford. WF10 5EJ. United Kingdom.</p>	<p>Brand: Busbi Designation: PLEV (Class 2) EN 17128 Model: Firefly (TT-EL-H853) DOM: May 2023 Max Speed: 15.5mph (25km/h) Max load: 100kg Net Wt: 12 kg IP Rating: IPX4 Battery: Lithium Ion. Max Input: 42V DC 1.5 Amp Capacity: 36VDC, 5.2Ah Motor: Rated Power: 250W Max Power: 350W</p>
<p>UK CA      FR Cet appareil se recycle A DÉPOSER EN MÉTALLURIE A DÉPOSER EN DÉCHÈTRIE OU Points de collecte sur www.quefairedesdechets.fr Privilégiez la réparation ou le don de votre appareil ! Made in China</p>	

Busbi Cable Lock Accessory. User Instructions

Note: This cable lock is intended for use in preventing unauthorised use of the Busbi Firefly scooter, and not specifically as an anti-theft device.

Setting the desired combination:



Ensure the factory setting '000' is centred in line with the interval marks on the casing.



Insert an implement such as an instrument screwdriver into the hole located on the edge of the lock casing.



Keeping upward pressure on the screwdriver, turn the thumbwheels to the desired combination centred in line with the interval marks on the casing.



Release and remove the screwdriver. Scramble the thumbwheels and then test the opening and closing of the lock using the set combination.

For more guidance and support to help you get started, please visit: busbistore.com/product-support, or simply open the camera app on your mobile phone, and point the camera at the QR code below:



BUSBI

Firefly

